







# STAGE PLOT 2023

- Drums: Kick, Snare, HH, 1 Rack Tom, 2 Floor Tom, 2 Crash, Ride
- Keyboard will provide own stereo "DI" interface (includes Acoustic & Elec Guitars)
- Elec Guitar has twin cabs (stereo), and own DI for acoustic
- Bass Guitar has twin (mono) cabs

 = Stage Power 120v

 = Direct Input XLR adapter

 = Wedge monitor

 = Microphone

 = Vocal Mic + Boom stand =

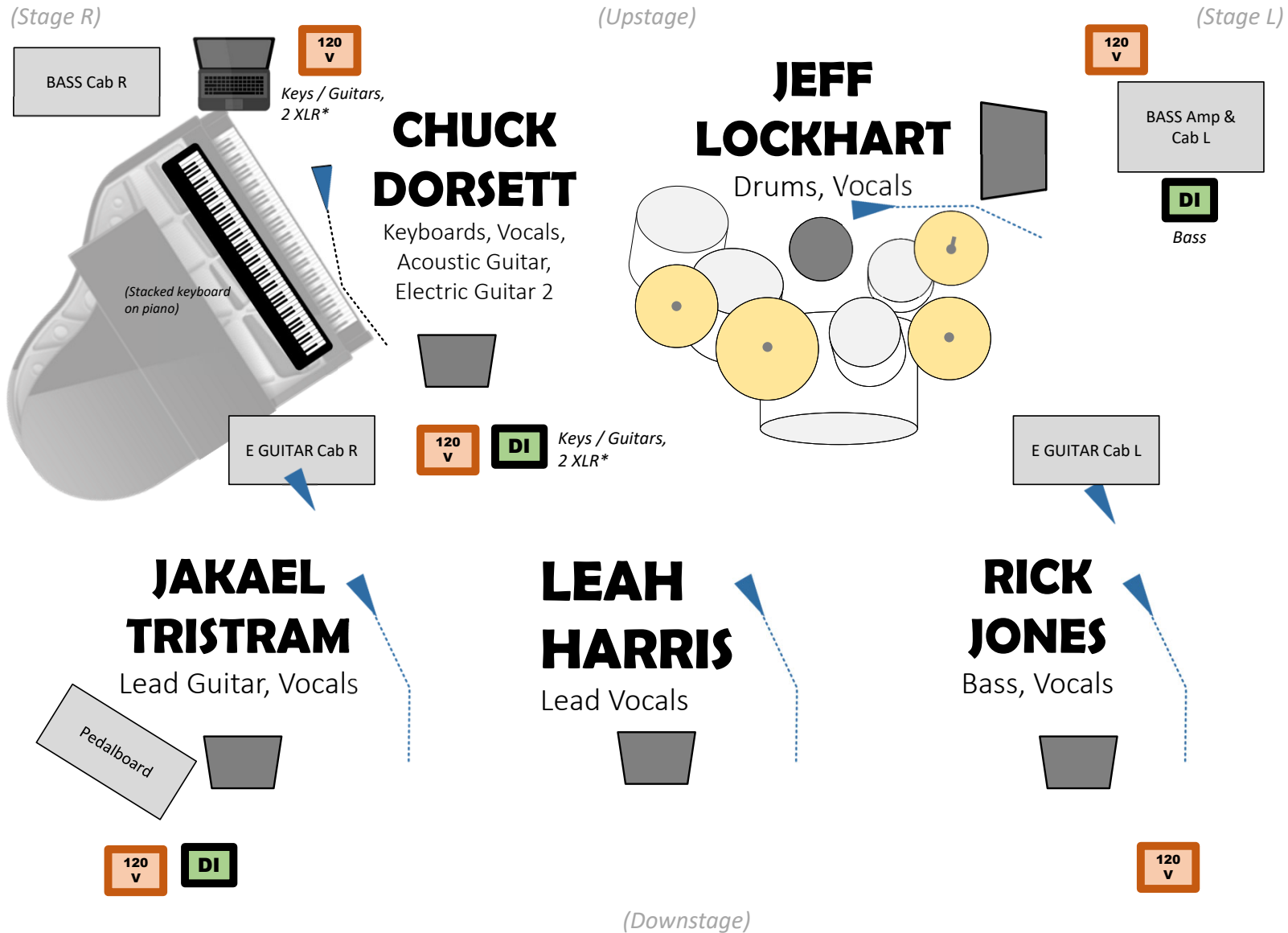



## INPUT LIST 2023

### Notes

- Keyboards will provide 1 or 2 XLR out from their interface (no DI)
- In 16-channel input configuration may omit:
  - Drum Overhead 2
  - Rack & Floor toms
- In 4-monitor mix configuration, Drummer is optional or can share with Keyboards.

#	INPUT	Note/Name
1	Kick Drum	
2	Snare Drum	
3	High Hat	
4	Rack Tom 1	
5	Floor Tom 1	
6	Floor Tom 2	
7	Drum Overhead L	
8	Drum Overhead R	
9	Electric Guitar L	
10	Electric Guitar R	
11	Piano	
12	Keyboards L	(Note: this includes
13	Keyboards R	Acoustic/Elec Gtr 2)
14	Bass Guitar	
15	E Gtr Vocal	Jakael
16	Keys Vocal	Chuck
17	Lead Vox Vocal	Leah
18	Drums Vocal	Jeff
19	Bass Vocal	Rick

#	MONITOR	Note/Name
1	E Gtr Monitor	Jakael
2	Keys Monitor	Chuck
3	Lead Vox Monitor	Leah
4	Drums Monitor	Jeff
5	Bass Monitor	Rick

### CONTACT

Jeff Lockhart  
Live Vinyl Productions

+ (425) 761-9549

[jeff@livevinylproductions.com](mailto:jeff@livevinylproductions.com)

<https://analogcatalog.com>

v20230222